

●ネジ端子形標準品

SCL シリーズ

JIS C5101
CE-33

■特徴

- ・産業用機器の大形電源、インバータ等を用途として開発したネジ端子形の大容量の製品です。
- ・従来品より一段と小形化されておりますが、定格リップル電流は同一水準になっております。

■寸法図/DIAGRAM OF DIMENSIONS

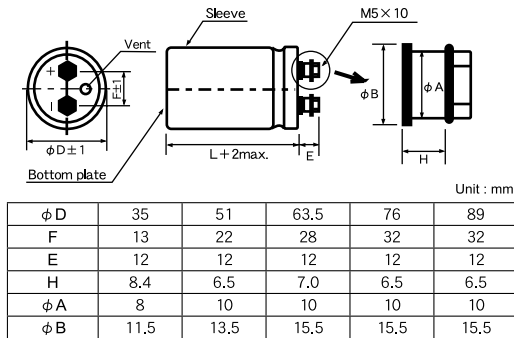

●SCREW TERMINAL STANDARDIZED TYPE

TYPE SCL JIS C5101
CE-33

■FEATURES

- ・ This is large capacitance product developed for use in power supply, inverter, etc. for industrial equipment.
- ・ Although this product is made compact much more than the conventional ones, its rated ripple current is on the same level as that of the conventional one.

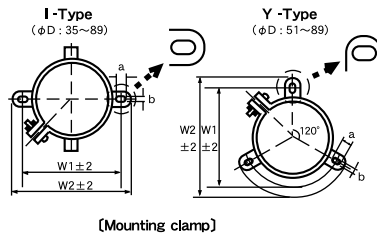

Clamp type	I				Y			
	a	b	W1	W2	a	b	W1	W2
φD								
35	6.0	3.2	50	62	-	-	-	-
51	6.0	4.5	68	80	4.5	7.0	63.5	73
63.5	6.0	4.5	81	93	4.5	7.0	76.2	85.1
76	6.0	4.5	93.5	106	4.5	7.0	88.9	98.4
89	7.0	5.0	108	120.5	4.5	7.0	101.6	111.1

■性能/PERFORMANCE SPECIFICATIONS

カテゴリ温度範囲	CATEGORY TEMPERATURE RANGE	-40°C ~ +85°C (≧315WV : -25°C ~ +85°C)
標準静電容量許容差	STANDARD CAPACITANCE TOLERANCE	-20% ~ +20% (25°C, 120Hz)
漏れ電流 (最大値)	LEAKAGE CURRENT (MAX. VALUE)	I=0.02CV OR 5mA WHICHEVER IS THE SMALLER (at 25°C, after 5 minutes) C=RATED CAPACITANCE (μF) V=WORKING VOLTAGE (V)
損失角の正接 (最大値) (25°C, 120Hz)	DISSIPATION FACTOR (MAX. VALUE) (25°C, 120Hz)	REFER TO CASE SIZE TABLES.
耐久性 85°C 2000時間 定格使用電圧印加	ENDURANCE APPLICATION OF RATED OPERATING VOLTAGE, AT 85°C FOR 2000HOURS.	CAPACITANCE CHANGE : LESS THAN 20% OF THE INITIAL MEASURED VALUE. DISSIPATION FACTOR : LESS THAN 200% OF THE INITIAL SPECIFIED VALUE. LEAKAGE CURRENT : LESS THAN THE INITIAL SPECIFIED VALUE.
その他の特性はJIS C5101-4に準ずる	THE OTHER CHARACTERISTICS	THE OTHER CHARACTERISTICS ARE BASED ON JIS C 5101-4

■定格リップル電流補正係数

リップル周波数が標準品一覧表の規定値と異なる場合には、下表の係数を乗じた値以下でご利用下さい。

When the ripple frequency differs from the specification shown in the list of standard products, multiply the value with the coefficient shown below, and use the products under the obtained value.

周波数補正係数/FREQUENCY CORRECTION FACTOR

WV	f(Hz)	50	120	300	1K	3K	5K	10K
10~50		0.95	1.0	1.04	1.10	1.12	1.13	1.15
63~100		0.95	1.0	1.06	1.16	1.20	1.25	1.30
160~200		0.90	1.0	1.10	1.20	1.35	1.40	1.50
250~450		0.80	1.0	1.10	1.20	1.35	1.40	1.50

■CASE SIZE CODE

φD	L	60	70	80	90	100	115	120	130	140	160
51		C060	C070	C080	C090	C100	C115	C120	C130		
64			D070	D080	D090	D100	D115	D120	D130	D140	
76				E080	E090	E100	E115	E120	E130	E140	E160
90				F080	F090	F100	F115	F120	F130	F140	F160

■品番ご指定法/HOW TO SPECIFY ITEM NUMBER FOR TYPE SCL

例/Example

160W.V

2C

定格電圧
Rated Voltage

例/Example

W.V	SYMBOL
80	1K
100	2A
160	2C
180	2P
200	2D

SCL series

SCL

シリーズ名
Series Name

例/Example

静電容量 RATED Cap. μF	記号 SYM- BOL	静電容量 RATED Cap. μF	記号 SYM- BOL
68	680	1200	122
82	820	1500	152
180	181	3300	332
270	271	12000	123

22000 μF

223

静電容量記号
Capacitance
Symbol

±20%

M

容量許容差
Capacitance
tolerance

±20%=M

φ90×90L

F090

サイズコード
Case size code

Y-type

Y

金具オプション
Clamp Option

不要=N
Without clamp
I型金具=I
With I-type clamp
Y型金具=Y
With Y-type clamp

■寸法表/CASE SIZE TABLE
■Ripple current [Max. Value A] at 85°C 120Hz.

μF \ W.V	10V (1A)						16V (1C)						25V (1E)																
100000				C060	1.5	7.0							C060	1.0	8.6			C080	0.80	10.3	D070	1.0	9.9						
120000				C060	1.5	7.7							C060	1.0	9.4			C090	0.80	11.7	D070	1.0	10.8						
150000				C060	1.5	8.6						C080	1.0	11.3	D070	1.5	9.9			C115	0.80	14.1	D080	1.0	12.5				
180000				C070	1.5	9.8						C090	1.0	12.8	D070	1.5	10.8			C120	0.80	15.7	D090	1.0	14.2	E080	1.2	13.5	
220000	C080	1.5	11.2	D070	2.0	10.4						C115	1.0	15.3	D080	1.5	12.3			D100	1.0	16.1	E080	1.2	14.9	-	-	-	
270000	C090	1.5	12.8	D070	2.0	11.5						C130	1.0	17.6	D090	1.5	14.2	E080	1.5	14.8	D115	1.0	18.6	E090	1.2	17.1	F080	1.2	17.5
330000	C115	1.5	15.3	D080	2.0	13.1						D115	1.5	16.8	E080	1.5	16.3	-	-	-	D140	1.0	21.9	E115	1.2	20.3	F080	1.2	19.4
390000	C130	1.5	17.3	D090	2.0	14.7	E8	2.0	15.4			D115	1.5	18.3	E090	1.5	18.4	F080	2.0	16.3	E115	1.2	22.0	F090	1.2	21.8			
470000	D100	2.0	16.7	E080	2.0	16.9	-	-	-			D140	1.5	21.3	E115	1.5	21.6	F080	2.0	17.9	E140	1.2	25.6	F100	1.2	24.6			
560000	D110	2.0	19.0	E090	2.0	19.1	F8	2.5	17.5			E115	1.5	23.6	F090	2.0	20.2			F115	1.2	27.9							
680000	D130	2.0	21.7	E100	2.0	21.6	F8	2.5	19.3			E140	1.5	27.6	F115	2.0	23.8			F140	1.2	32.5							
820000	E115	2.0	24.7	F090	2.0	21.9						F130	2.0	27.1															

μF \ W.V	35V (1V)						50V (1H)						63V (1J)																		
27000				C060	0.60	5.8							C060	0.50	6.3			C070	0.40	7.4	-	-	-								
33000				C060	0.60	6.4							C070	0.50	7.3			C080	0.40	8.4	D070	0.50	8.0								
39000				C060	0.60	6.9						C080	0.50	8.1	D070	0.60	8.0			C090	0.40	9.5	D070	0.50	8.7						
47000				C070	0.60	7.9						C090	0.50	9.3	D070	0.60	8.8			C115	0.40	11.3	D080	0.50	9.9						
56000	C070	0.60	8.6	-	-	-						C100	0.50	10.5	D070	0.60	9.6			C130	0.40	12.8	D090	0.50	11.2	E080	0.50	11.7			
68000	C080	0.60	9.8	D070	0.80	9.1						C115	0.50	12.0	D080	0.60	10.9			D100	0.50	12.7	E080	0.50	12.9	-	-	-			
82000	C100	0.60	11.6	D070	0.80	10.0						C130	0.50	13.7	D090	0.60	12.3	E080	0.60	12.9	D115	0.50	14.5	E090	0.50	14.6	F080	0.60	13.7		
100000	C115	0.60	13.3	D080	0.80	11.4						D115	0.60	14.7	E090	0.60	14.7	F080	0.80	13.1	D130	0.50	16.7	E100	0.50	16.6	F080	0.60	15.1		
120000	C120	0.60	14.8	D090	0.80	12.9	E080	1.0	12.1			D130	0.60	16.7	E100	0.60	16.6	F080	0.80	14.3	E115	0.50	18.9	F090	0.60	17.1					
150000	D100	0.80	14.9	E080	1.0	13.5	-	-	-			E115	0.60	19.3	F090	0.80	16.5			E140	0.50	22.4	F100	0.60	19.6						
180000	C115	0.80	17.0	E090	1.0	15.3	F080	1.0	15.7			E130	0.60	21.9	F100	0.80	18.6			F115	0.60	22.4									
220000	C140	0.80	20.0	E115	1.0	18.1	F090	1.0	17.9			F115	0.80	21.4						F140	0.60	26.2									
270000	E120	1.0	20.3	F100	1.0	20.4						F130	0.80	24.6																	
330000	E140	1.0	23.5	F115	1.0	23.5																									
390000	F130	1.0	26.4																												
470000	F140	1.0	29.6																												

μF \ W.V	80V (1K)						100V (2A)																								
12000 (123)				C060	0.30	5.5						C070	0.25	6.4	-	-	-														
15000 (153)				C060	0.30	6.2							C080	0.25	7.0	D070	0.30	7.0													
18000 (183)				C070	0.30	7.0							C090	0.25	8.3	D070	0.30	7.7													
22000 (223)	C080	0.30	8.0	D070	0.40	7.3							C115	0.25	10.0	D080	0.30	8.7													
27000 (273)	C090	0.30	9.2	D070	0.40	8.1							C130	0.25	11.5	D100	0.30	10.3	E080	0.35	9.7										
33000 (333)	C100	0.30	10.5	D080	0.40	9.3							D115	0.25	11.9	E090	0.35	11.1	F080	0.35	11.4										
39000 (393)	C115	0.30	12.0	D090	0.40	10.4	E080	0.40	10.9				D130	0.25	13.4	E100	0.35	12.4	F080	0.35	12.3										
47000 (473)	C130	0.30	13.6	D100	0.40	10.0	E080	0.40	11.9				E115	0.35	14.2	F090	0.35	14.0													
56000 (563)	D115	0.40	13.4	E090	0.40	13.5	F080	0.40	13.8				E120	0.35	16.0	F100	0.35	15.7													
68000 (683)	D130	0.40	15.4	E100	0.40	15.3	F080	0.40	15.2				E160	0.35	18.8	F110	0.35	18.0													
82000 (823)	E115	0.40	17.5	F090	0.40	17.3							F130	0.35	20.5																
100000 (104)	E140	0.40	20.5	F100	0.40	19.6							F160	0.35	24.0																
120000 (124)	F115	0.40	22.4																												
150000 (154)	F140	0.40	26.5																												

Case size code

 $\tan \delta$ (25°C, 120Hz)

Ripple current

■寸法表 /CASE SIZE TABLE

■ Ripple current [Max. Value A] at 85°C 120Hz.

μF	W.V	160V (2C)						180V (2P)						200V (2D)													
3900				C060	0.25	4.5				C070	0.25	4.8	-	-	-			C080	0.25	5.0	D070	0.25	5.3				
4700	C070	0.25	5.2	-	-	-				C080	0.25	5.4	D070	0.25	5.7			C090	0.25	5.7	D070	0.25	5.9				
5600	C080	0.25	5.9	D070	0.25	6.2				C090	0.25	6.1	D070	0.25	6.3			C100	0.25	6.4	D070	0.25	6.4				
6800	C090	0.25	6.7	D070	0.25	6.8				C100	0.25	7.0	D070	0.25	6.9			C115	0.25	7.4	D080	0.25	7.3				
8200	C100	0.25	7.6	D070	0.25	7.5				C115	0.25	8.0	D080	0.25	8.1	E080	0.25	8.1	C130	0.25	8.4	D090	0.25	8.3	E080	0.25	8.2
10000	C115	0.25	8.8	D090	0.25	8.8	E080	0.25	8.8	C130	0.25	9.2	D100	0.25	9.2	E080	0.25	8.9	D115	0.25	9.8	E090	0.25	9.3	F080	0.25	9.4
12000	C130	0.25	10.0	D100	0.25	10.0	E080	0.25	9.7	D115	0.25	10.5	E090	0.25	10.1	F080	0.25	10.2	D130	0.25	11.2	E100	0.25	10.5	F080	0.25	10.2
15000	D115	0.25	11.6	E090	0.25	11.2	F080	0.25	11.5	D130	0.25	12.2	E100	0.25	11.6	F080	0.25	11.5	E115	0.25	12.3	F090	0.25	11.8			
18000	D130	0.25	13.2	E100	0.25	12.6	F080	0.25	12.6	E115	0.25	13.2	F090	0.25	13.3			E130	0.25	13.9	F100	0.25	11.3				
22000	E115	0.25	14.5	F090	0.25	14.3				E140	0.25	15.5	F100	0.25	14.7			F115	0.25	15.3							
27000	E140	0.25	17.0	F100	0.25	16.3				F115	0.25	17.0						F140	0.25	18.0							
33000	F130	0.25	19.4							F140	0.25	19.9															
39000	F140	0.25	21.6																								

μF	W.V	250V (2E)						315V (2F)						350V (2V)													
1200				C060	0.20	3.3				C060	0.20	3.4						C060	0.20	3.9							
1500				C060	0.20	3.7				C060	0.20	3.8				C070	0.20	4.5	-	-	-						
1800				C060	0.20	4.1				C070	0.20	4.3				C080	0.20	5.1	D070	0.20	5.4						
2200				C070	0.20	4.7				C080	0.20	4.9	D070	0.20	5.3			C090	0.20	5.8	D070	0.20	6.0				
2700	C080	0.20	5.3	D070	0.20	5.8				C090	0.20	5.7	D070	0.20	5.9			C100	0.20	6.7	D080	0.20	6.9				
3300	C090	0.20	6.1	D070	0.20	6.4				C100	0.20	6.5	D080	0.20	6.7			C115	0.20	7.7	D090	0.20	7.9	E080	0.20	8.2	
3900	C100	0.20	6.9	D070	0.20	6.9				C115	0.20	7.3	D090	0.20	7.5	E080	0.20	7.8	D100	0.20	8.8	E080	0.20	8.9	-	-	-
4700	C115	0.20	7.9	D080	0.20	7.8				C130	0.20	8.4	D100	0.20	8.5	E080	0.20	8.6	D115	0.20	10.1	E090	0.20	10.1	F080	0.20	10.4
5600	C130	0.20	8.9	D090	0.20	8.9	E080	0.20	8.7	D115	0.20	9.7	E090	0.20	9.7	F080	0.20	10.0	D130	0.20	11.4	E100	0.20	11.4	F008	0.20	11.4
6800	D115	0.20	10.5	E080	0.20	9.5	-	-	-	D130	0.20	11.1	E100	0.20	11.0	F080	0.20	11.0	E115	0.20	13.1	F090	0.20	12.9			
8200	D130	0.20	12.0	E090	0.20	10.8	F080	0.20	10.9	E115	0.20	12.6	F090	0.20	12.4			E140	0.20	15.2	F100	0.20	14.6				
10000	D140	0.20	13.5	E115	0.20	12.8	F080	0.20	12.1	E140	0.20	14.7	F100	0.20	14.1			F115	0.20	16.8							
12000	E130	0.20	14.6	F090	0.20	13.6				F115	0.20	16.1						F140	0.20	19.4							
15000	E140	0.20	16.6	F115	0.20	16.3				F140	0.20	19.1															
18000	F130	0.20	18.5																								
22000	F160	0.20	21.7																								

μF	W.V	400V (2G)						450V (2W)										
1000				C060	0.20	3.5				C070	0.25	3.6	-	-	-			
1200				C070	0.20	4.0				C080	0.25	4.0	D070	0.25	4.3			
1500	C080	0.20	4.6	D070	0.20	5.0				C090	0.25	4.7	D070	0.25	4.8			
1800	C090	0.20	5.3	D070	0.20	5.4				C115	0.25	5.5	D080	0.25	5.4			
2200	C100	0.20	6.0	D080	0.20	6.2				C130	0.25	6.3	D090	0.25	6.2	E080	0.25	6.5
2700	C115	0.20	7.0	D090	0.20	7.1	E080	0.20	7.4	D100	0.25	7.1	E080	0.25	7.2	-	-	-
3300	D100	0.20	8.1	E080	0.20	8.2	-	-	-	D115	0.25	8.2	E090	0.25	8.2	F080	0.25	8.5
3900	D115	0.20	9.2	E090	0.20	9.2	F080	0.20	9.5	D140	0.25	9.5	E115	0.25	9.6	F080	0.25	9.2
4700	D130	0.20	10.5	F080	0.20	10.4				E130	0.25	10.9	F080	0.25	10.4			
5600	E115	0.20	11.9	F090	0.20	11.7				E140	0.25	12.2	F100	0.25	11.7			
6800	E140	0.20	13.8	F100	0.20	13.3				F115	0.25	13.4						
8200	F115	0.20	15.2							F140	0.25	15.6						
10000	F140	0.20	17.7															

Case size code tan δ (25°C, 120Hz) Ripple current

●この寸法表にないカスタム製品も製造いたしますので、御相談下さい。 ● Produce custom products too, which are not found in these tables.